

WHITLEY PLACE - PATH EXPANSION

DRAWING INDEX:

1. COVER PAGE
2. GENERAL NOTES & DESIGN DETAILS
3. PROPOSED WORKS

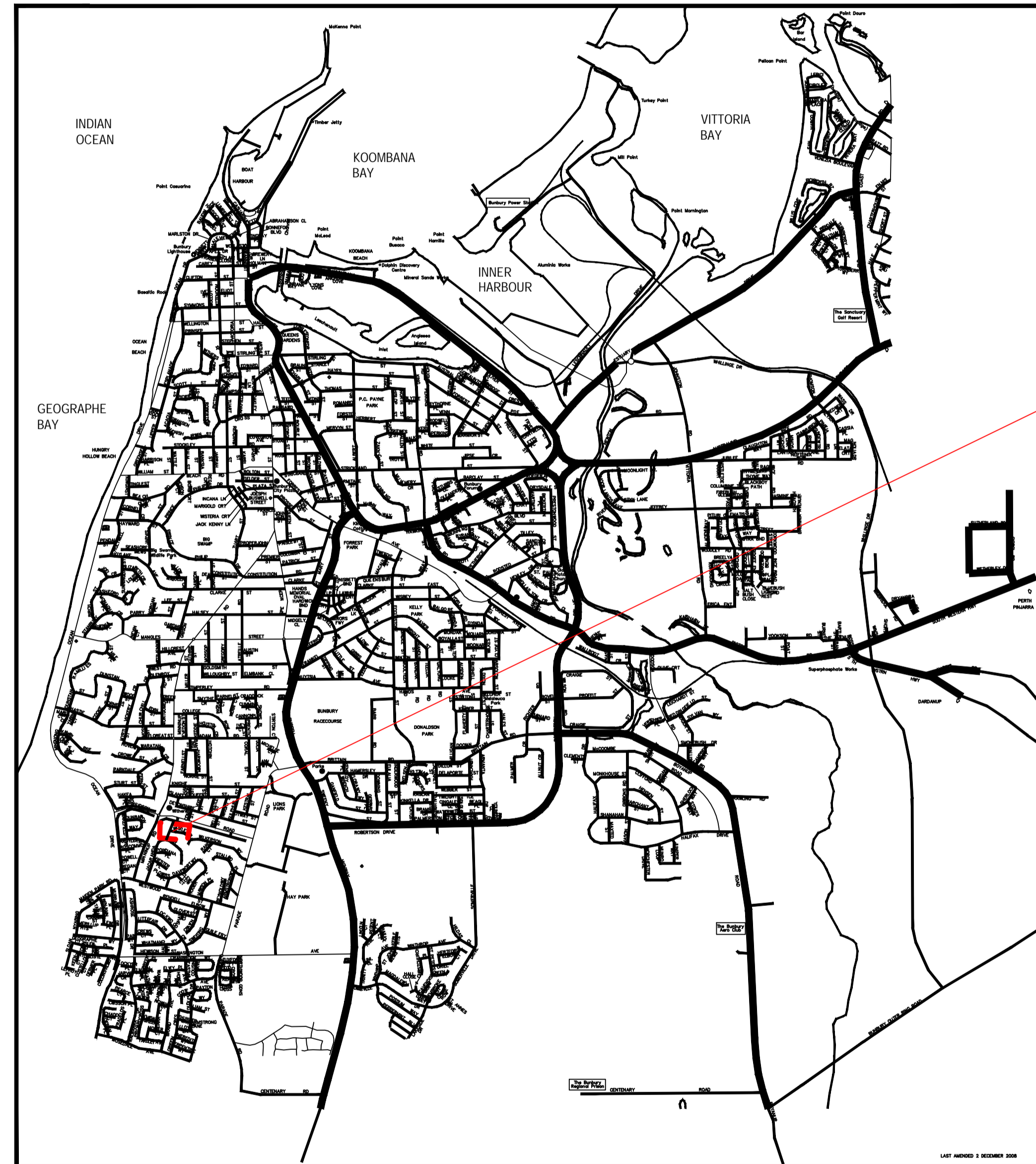

LOCALITY PLAN
SCALE: NTS



AMENDMENTS	REV	DATE	DESCRIPTION	DRAWN
	A	06/2024	ISSUED FOR APPROVAL	RD

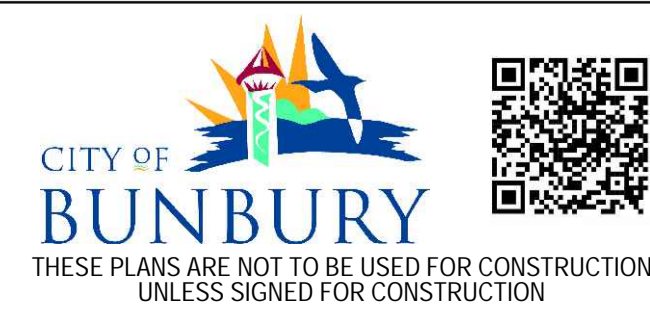

SIGNATURES:		DATUM V: AHD71	DATUM H: MGA94	DRAWING NO:
DESIGNED BY: RUVINDU DON	APPROVED BY: AARON LINDSAY	SURVEYOR: KELLEEE NUNN		1-2023-034
DATE SIGNED: 19/06/2024	DATE SIGNED: 09/07/2024			SHEET: 1 OF 3
DRAWING FILENAME: N:\Assets & Design\Projects\Path\23-24\Whitley Place PAW Path\Design				SCALE: AS SHOWN

ISSUED FOR APPROVAL	
WHITLEY PLACE - PATH EXPANSION	COVER PAGE

REV. A	A1
CM10 FOLDER:	COB/6648

A. GENERAL NOTES

*REMEMBER - DIAL 1100 - BEFORE YOU DIG

- DISTANCES SHALL NOT BE SCALED FROM THE DRAWINGS. ALL DIMENSIONS SHALL BE VERIFIED ON SITE PRIOR TO COMMENCEMENT OF WORKS.
- CONTRACTOR/SUPERVISOR IS TO PREPARE AN APPROVED TRAFFIC MANAGEMENT PLAN PRIOR TO COMMENCEMENT OF WORKS.
- CONTRACTOR/SUPERVISOR IS TO LOCATE ALL SERVICES PRIOR TO COMMENCEMENT OF WORKS. LINES ON PLANS ARE DIAGRAMMATIC ONLY. ANY SUSPECTED CLASHES ARE TO BE REPORTED TO THE DESIGNER IMMEDIATELY.
- PROPERTY BOUNDARIES SHOWN ON THIS DRAWING ARE SCHEMATIC ONLY.
- SHOULD DISCREPANCIES EXIST BETWEEN THE SITE AND DRAWINGS PLEASE CONTACT THE DESIGNER.
- ALL RESIDENTS AFFECTED BY THE PROPOSED WORKS SHALL BE NOTIFIED IN WRITING BY THE CITY OF BUNBURY 14 DAYS PRIOR TO COMMENCEMENT OF WORKS.
- SHOULD THE DESIGN REQUIRE CHANGES PLEASE ADVISE THE DESIGNER SO THE DRAWING CAN BE AMENDED.
- VEHICULAR ACCESS TO ADJOINING PROPERTIES SHALL BE MAINTAINED WHEREVER POSSIBLE FOR THE DURATION OF THE WORKS. WHERE VEHICULAR ACCESS IS TO BE RESTRICTED TO ENABLE WORKS TO PROCEED. ALL AFFECTED RESIDENTS SHALL BE NOTIFIED PRIOR TO ACCESS BEING RESTRICTED. ALL PROPERTIES SHALL HAVE VEHICULAR ACCESS REINSTATED AT THE COMPLETION OF EACH DAYS WORK.
- CLEAN UP THE ENTIRE WORKSITE ON COMPLETION.
- THESE NOTES APPLY TO ALL DRAWINGS LISTED ON THE DRAWING INDEX.

B. CLEARING AND DEMOLITION NOTES

- ENVIRONMENTAL CLEARANCE SHALL BE SOUGHT FROM THE CONCERNED AUTHORITY PRIOR TO THE REMOVAL OF VEGETATION.
- ALL VEGETATION SHALL BE CLEARED AND MOVED TO CITY'S NOMINATED SITE OR BE MULCHED AND SPREAD ON THE SITE AS DIRECTED BY THE CITY.
- ALL WASTE MATERIALS GENERATED FROM THE SITE CLEARANCE SHALL BE REMOVED TO THE CITY'S NOMINATED SITE.
- EXISTING VERGES SHALL NOT BE DISTURBED BEYOND THE EXTENT OF WORK. ANY DAMAGE OCCURRED AT THE SITE SHALL BE REPORTED AND REINSTATED TO THE SATISFACTION OF THE CITY.

G. PATH NOTES

- CONCRETE TO BE USED FOR PATH SHALL CONFORM TO THE SAME SPECIFICATION AS THAT OF KERBING WORKS.
- ALL KERB RAMPS TO BE TYPE 'A'.
- ALL PATHS SHALL BLEND TO EXISTING PATH OR KERB UNLESS NOTED OTHERWISE.
- ALL DRIVEWAYS TO BE REGRADED TO ALIGN WITH NEW PATH HEIGHT.
- NEW PATH IS TO BE MINIMUM OF 1.5m WIDE AND 100mm THICK UNLESS NOTED OTHERWISE.
- ADJUST RETICULATION SYSTEMS IN VERGE TO ACCOMMODATE NEW PATH.
- PATH TO FALL 1-2% TOWARDS THE LOWER END OF GROUND.
- REFER STANDARD DRAWING No. 7-2002-001 - SHEETS 1-3 FOR PATH AND RAMP CONSTRUCTION DETAILS.
- ROOT BARRIER TO BE INSTALLED WHERE TREE ROOTS ARE SEVERED OR TREES WITHIN 2m OF PATH.
- ALL TREES THAT REQUIRE PRUNING SHALL BE PRUNED TO ALLOW FOR 2.2m HEADROOM OVER PATH.
- REFER MAIN ROADS DRAWING NO. 200931-0089 FOR INSTALLATION OF TACTILE GROUND SURFACE INDICATOR.

H. DRAINAGE NOTES

- ALL DRAINAGE INSTALLATIONS TO BE IN ACCORDANCE WITH AS3500.
- ALL PRECAST COMPONENT (PIPES, LIDS, LINERS AND BASES) SHALL BE PROCURED FROM THE APPROVED MANUFACTURER AND ARE TO BE INSTALLED AS PER THE MANUFACTURER'S GUIDELINES.
- CONCRETE SHALL BE 20mm NOM. AGGREGATE AND HAVE A MINIMUM STRENGTH AT 28 DAYS OF:
INSITU BASE - 20MPa
PRECAST UNIT - 40MPa
- MORTAR SHALL BE 4 SAND: 1 CEMENT.
- WHERE MANHOLES ARE CONSTRUCTED IN ROAD PAVEMENT, A CONVERSION SLAB SHALL BE USED TO BRING THE OPENING BACK TO A 610 x 610 OPENING WITH A MINIMUM OF TWO (2) COURSES OF BRICKWORK UNDER COVER AND SURROUND.
- BOLT ON GALVANISED STEP IRONS AT 300 CTRS SHALL BE INSTALLED IN ALL DRAINAGE PITS WHERE DEPTH FROM TOP OF COVER TO TOP OF BASE EXCEEDS 1200mm.
- SOIL FROM TRENCH TO BE DISPOSED OFF AT AUTHORISED SITE FOR ACID SULPHATE SOILS. BACK FILL TO BE CLEAN SAND FREE FROM CLAY AND DELETERIOUS MATTER.
- SUBGRADE TO BASE SHALL BE COMPACTED TO 96% MMDD BEFORE PLACING BASE.
- BEFORE THE GENERAL BACKFILL OF THE TRENCH IS COMMENCED, ALL MANHOLES AND SPACES AROUND THE UTILITY INSTALLED, SHALL BE CAREFULLY COMPACTED WITH HAND RAMMERS. THE MINIMUM DEPTH OF INITIAL HAND COMPACTION ABOVE THE CROWN OF THE PIPE SHALL BE NO LESS THAN 150mm.
- COMPACTION OF THE REMAINING BACKFILL SHALL BE IN 150mm LAYERS. COMPACTION SHALL BE ACHIEVED BY MECHANICAL MEANS WITH WATER TO A DENSITY OF NOT LESS THAN 96% OF THE MAXIMUM DRY DENSITY WHEN TESTED IN ACCORDANCE WITH AS1289.5.2.1-2003. MEASUREMENT USING A PROPERLY CALIBRATED STANDARD PERTH PENETROMETER WOULD BE ACCEPTABLE OR AT LEAST EQUAL TO THAT OF THE SURROUNDING UNDISTURBED ROAD MATERIAL.
- PIPE SHALL FINISH FLUSH WITH EXTERNAL FACE OF HEADWALL AND GAPS BETWEEN HEADWALL AND PIPE SHALL BE FILLED WITH 3:1 SAND/CEMENT MORTAR.
- HEADWALL SHALL EXTEND TO MATCH WITH EXISTING ALIGNMENT AND SLOPE.

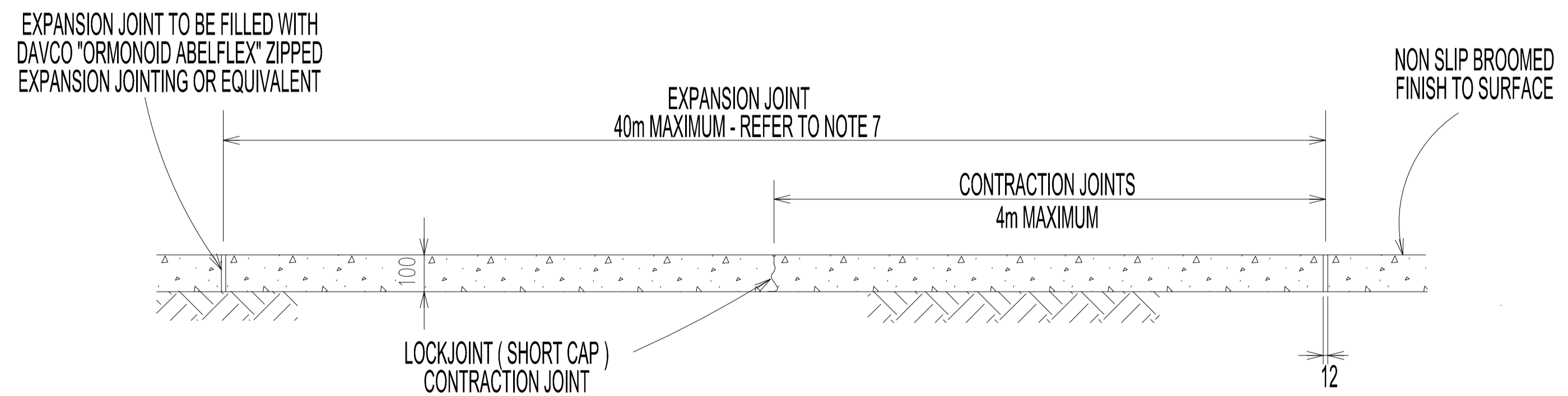
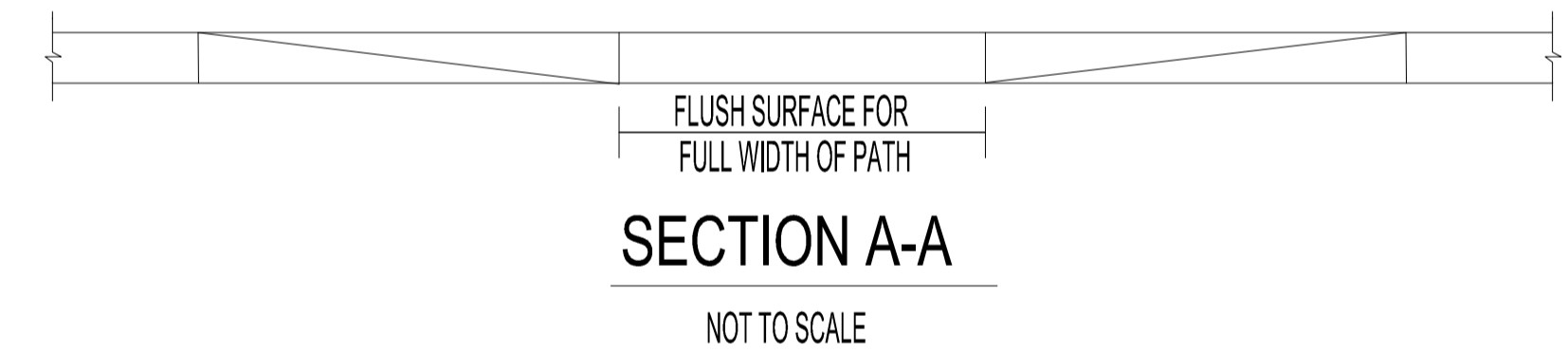
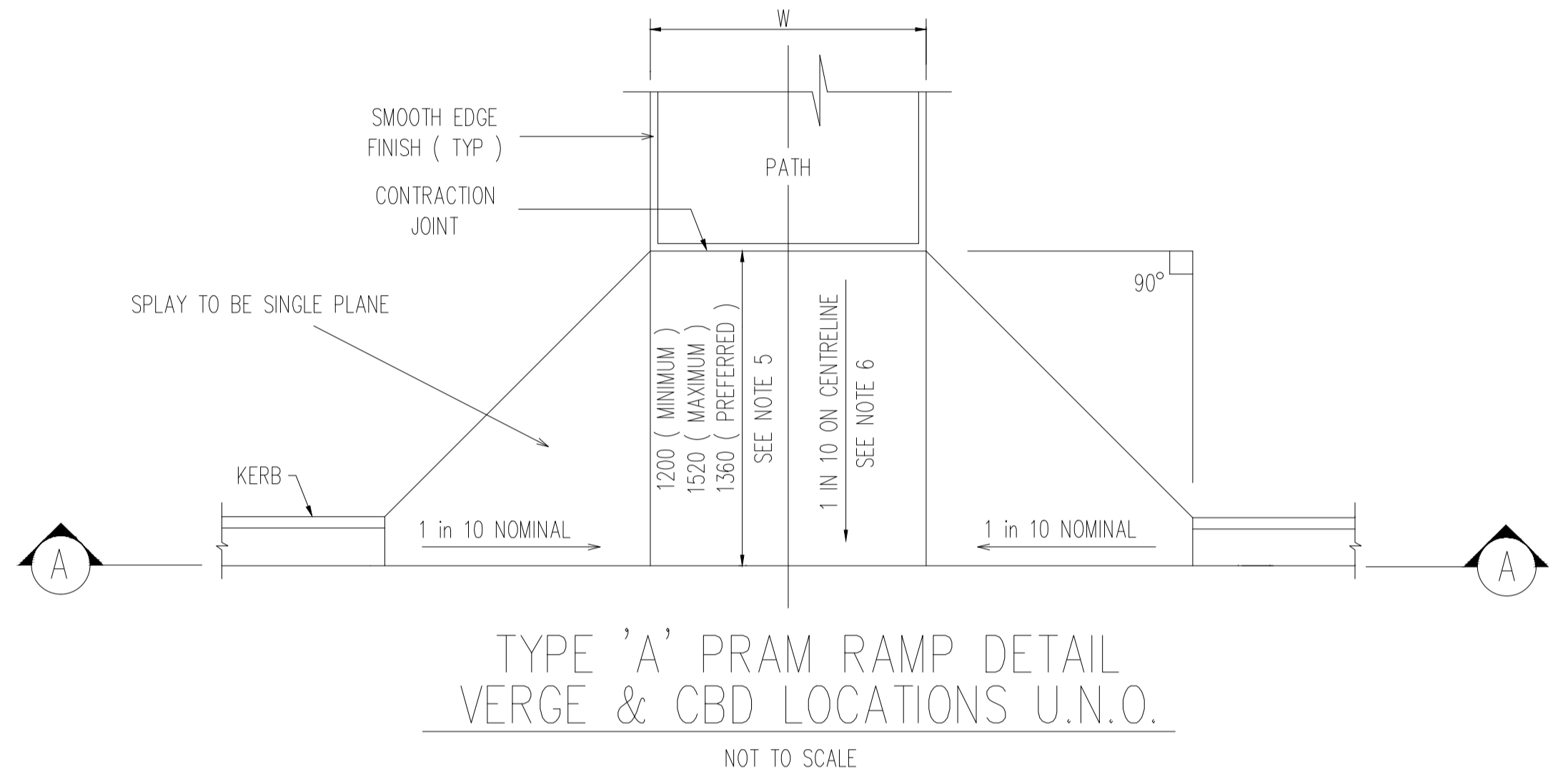
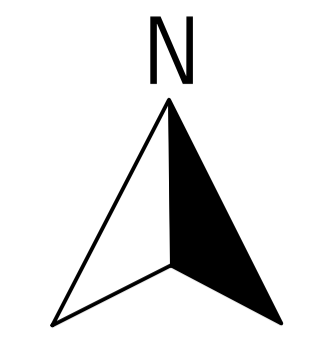
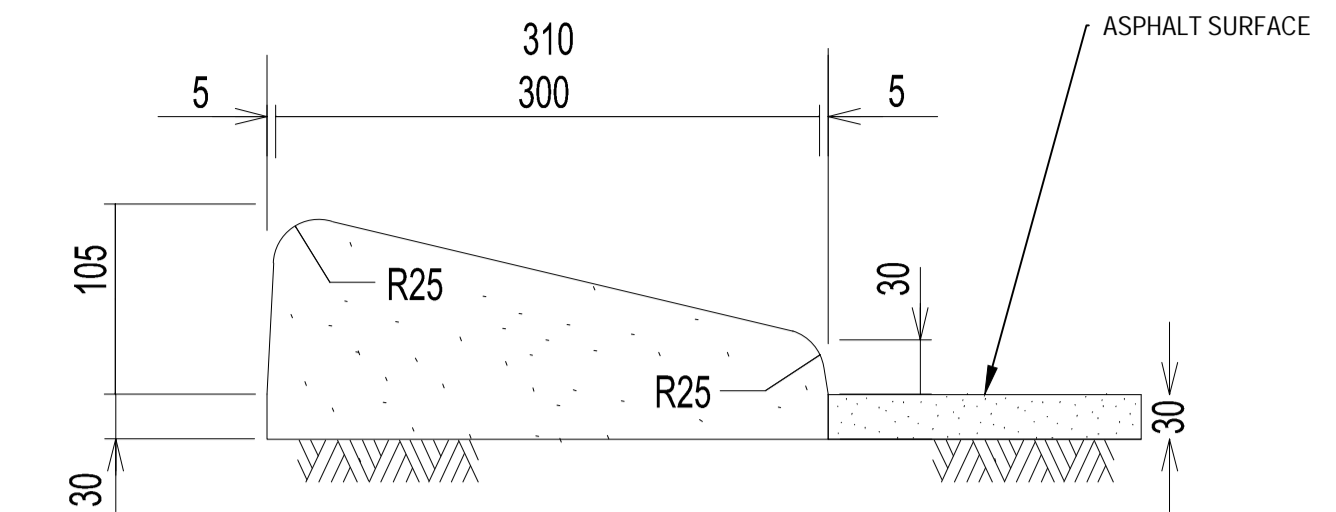
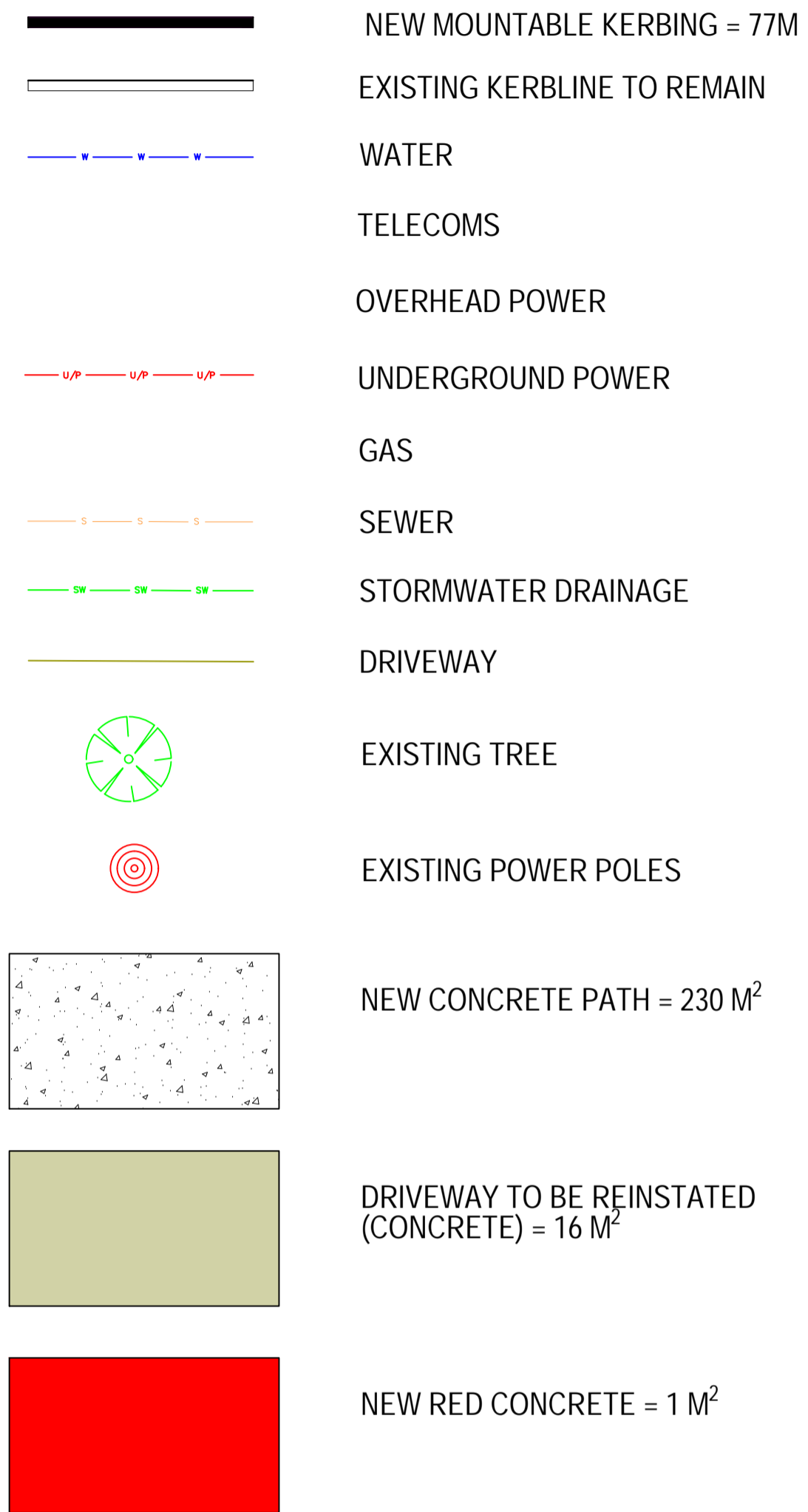

AMENDMENTS	REV	DATE	DESCRIPTION	DRAWN
	A	06/2024	ISSUED FOR REVIEW	RD
	REV	DATE	DESCRIPTION	DRAWN



SIGNATURES:	
DESIGNED BY: RUVINDU DON	APPROVED BY: AARON LINDSAY
DATE SIGNED: 19/06/2024	DATE SIGNED: 09/07/2024
DRAWING FILENAME: N:\Assets & Design\Projects\Path\23-24\Whitley Place PAW Path\Design	

DATUM V: AHD71	DATUM H: MGA94
SURVEYOR: KELLEENUNN	

DRAWING NO:	
1-2023-034	
SHEET:	SCALE:
2 OF 3	N/A

ISSUED FOR APPROVAL		A1
WHITLEY PLACE - PATH EXPANSION GENERAL NOTES & DESIGN DETAIL		REV. 0 CM10 FOLDER: COB/648

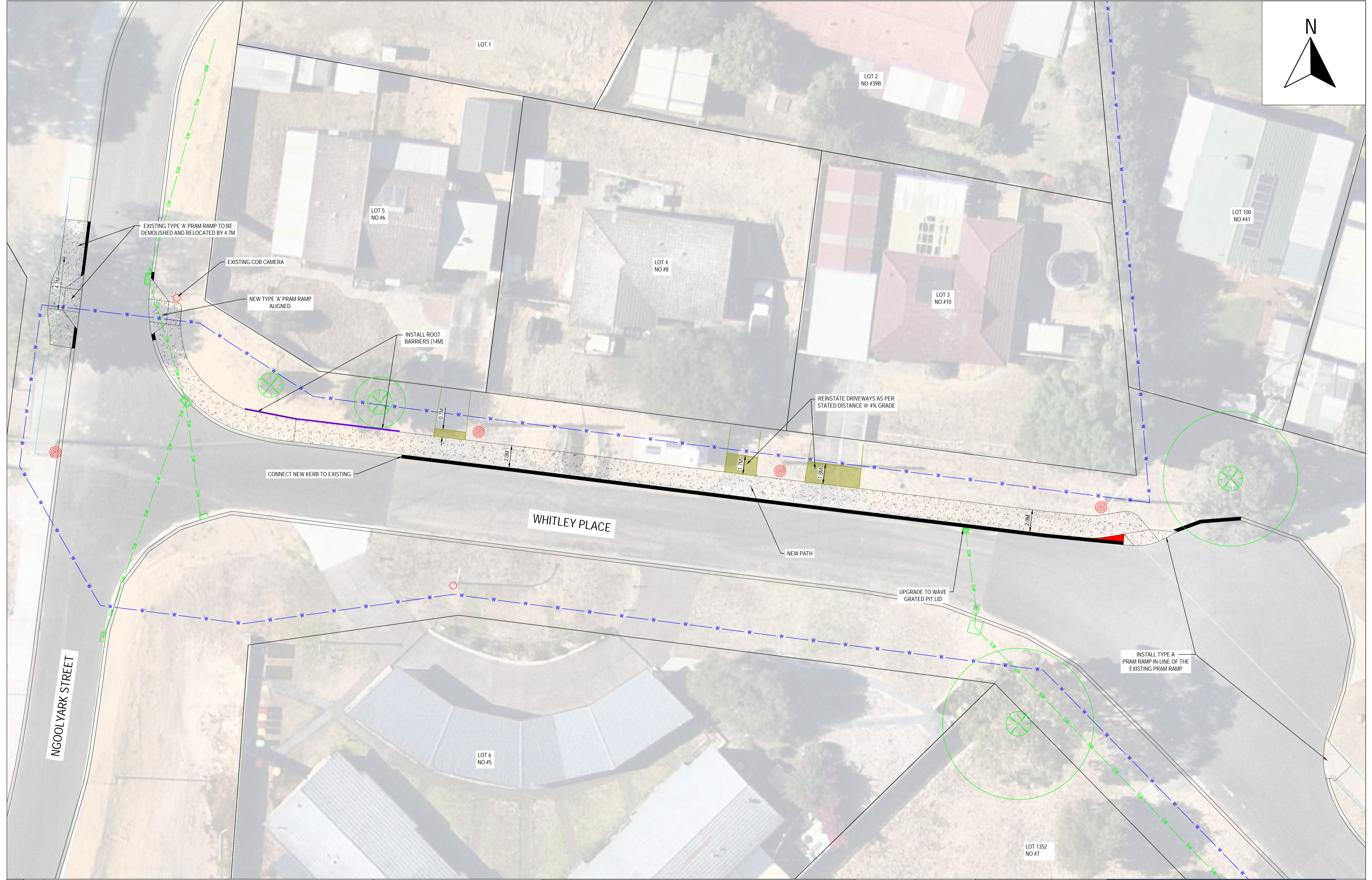
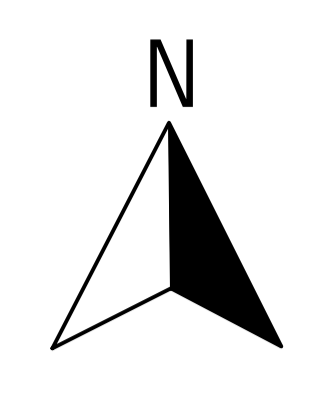

AMENDMENTS	REV	DATE	DESCRIPTION	RD	DRAWN
	A	19/2024	ISSUED FOR REVIEW		

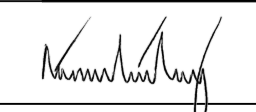

 THESE PLANS ARE NOT TO BE USED FOR CONSTRUCTION UNLESS SIGNED FOR CONSTRUCTION

SIGNATURES:	
DESIGNED BY: RUVINDU DON	APPROVED BY: AARON LINDSAY
DATE SIGNED: 19/05/2024	DATE SIGNED: 09/07/2024
	
DRAWING FILENAME: N:\Assets & Design\Projects\Path23-24\Whitley Place PAW Path\Design	

DATUM V: AHD71	DATUM H: MGA94
SURVEYOR: KELLEE NUNN	

DRAWING NO:	
1-2023-034	
SHEET:	SCALE:
3 OF 3	1:150

ISSUED FOR APPROVAL

WHITLEY PLACE - PATH EXPANSION
PROPOSED WORKS

A1
REV. 0
CM10 FOLDER:
COB/6648