



City of Bunbury

Requirements for the Establishment, Construction and Fit Out of Food Premises

City of Bunbury Environmental Health Services

PO Box 21 BUNBURY WA 6231

T 08 9792 7100

W www.bunbury.wa.gov.au E info@bunbury.wa.gov.au

Current as at July 2023

Introduction

This information package has been developed to assist food business proprietors (new and existing), architects, designers and builders to comply with *National Food Safety Standard 3.2.3 Food Premises and Equipment (FSS 3.2.3)*, for the construction and fit out of new food premises or alterations to existing food premises, and to explain the approval processes required.

Australian Standard AS 4674-2004 *Design, Construction and Fit Out of Food Premises* (AS 4674-2004) provides design, construction and fit-out criteria for new food premises and for the renovation or alteration of existing food premises. The scope of the Standard is limited to permanent buildings used by the food service industry, food retailers and small-scale food manufacturers.

The City of Bunbury recommends compliance with AS 4674-2004 for food businesses to meet the requirements of FSS 3.2.3. The standard establishes minimum requirements that are outlined generally in the attached information.

For detailed information copies of AS 4674-2004, please see:

Standards Australia

T: 1300 654 645

<https://www.foodstandards.gov.au/Pages/default.aspx>

Due to copyright restrictions the City is unable to provide copies of the standard. AS 4674-2004 is available for viewing at the Bunbury City Library, Parkfield Street, Bunbury, and at the City's Administration office at 4 Stephen Street, Bunbury during business hours.

The following general information in relation to the requirements of AS 4674-2004 is provided as a guide only. Please note, it is your responsibility as a food business to comply with all legislative requirements. Please refer to the standard for more specific information.

Council Approval Processes

The establishment of a new food business may require approval from a number of Council departments:

Planning Services (T 08 9792 7000)

Planning approval is the first step in setting up a new food business. Planning Services will ascertain the suitability of the food business in the proposed location. You will need to consult with a Planning Officer to determine if a development application is required to be submitted.

Building Services (T 08 9792 7000)

If you are constructing a new premises or making changes to an existing premises, you may be required to submit a building permit application. You will need to discuss your proposal with a Building Surveyor to determine if this is necessary.

Compliance Services (T 08 9792 7000)

If you are proposing to install new signage, you may be required to submit a Sign Application. Please contact a Compliance Officer to determine requirements in relation to signage.

Environmental Health Services (T 08 9792 7100)

All new food businesses and alterations/extensions to existing food businesses are required to be assessed and approved by Environmental Health Services, even if Planning and Building approvals are not necessary.

An Application for Environmental Health Services Approval (available from the City's website – <https://www.bunbury.wa.gov.au/live/handbook/environmental-health-services/environmental-health-forms-and-licenses>) and one complete set of scaled plans (minimum 1:100) detailing the design and fit out specifications for areas in which food is to be handled, prepared, stored etc shall be provided for assessment and approval prior to commencing fit out.

The plans and specifications shall include the following details:

- the use of every room/area
- the structural finishes of walls, floors, ceilings, benches, shelves and other surfaces
- the position and type of all fixtures, fittings and equipment
- all sanitary conveniences, floor wastes/bucket traps/cleaner's sinks, grease traps and the like
- waste storage and disposal areas
- plans and specifications of the mechanical exhaust system if cooking is to take place in the food business
- specifications of all cooking equipment (stoves, ovens, fryers and the like)
- elevations of food handling and storage areas
- details of the types of food being prepared and/or sold

On completion of construction or alterations and prior to opening to the public, you are required to contact the City on T 9792 7100 to arrange for an Environmental Health Officer to undertake a final inspection for compliance with the approved plans and any conditions of approval.

Should you wish to apply for a liquor licence for the premises, you will need to contact the Department of Racing, Gaming & Liquor:

W: www.dlgsc.wa.gov.au/racing-gaming-and-liquor

T: 1800 634 541

Fees for Food Businesses

The following fees apply in relation to the operation of a food business:

- Application fee for Environmental Health Services approval
- Registration fee (once off fee)
- Food business assessment fee
 - high risk premises
 - medium risk premises
 - low risk premises(per annum)

Copies of up-to-date Fees and Charges can be found on the City's website [here](#).

An Environmental Health Officer will undertake a risk assessment of the food business and advise the proprietor in writing of the risk classification.

A Food Business Registration Form can be downloaded from the City's website [here](#) or by contacting Environmental Health Services on T 08 9792 7100.

Design and Construction Requirements

Design of the food premises

Consider the pattern of food flow to ensure adequate space is provided and enable operational efficiencies. Take into account the amount of storage space needed for dry foods, fruit and vegetables, cooking equipment, crockery etc. Assess refrigeration storage requirements. Sufficient area needs to be allocated for storing clothing and personal effects of staff (a change room may be required), storage of refuse and recycling, cleaning materials, chemicals and the like.

Premises shall be pest proof

Holes and difficult to access spaces are required to be sealed. Pest control devices are to be located so that they do not contaminate food.

Adequate supply of potable water shall be provided

Food businesses must have an adequate supply of potable water for all activities that use water. Warm water is required for hand washing facilities and for washing equipment. A hot water system will be needed to achieve the temperature requirements of the standards.

Effective disposal of sewage and waste water

Grease trap shall be located away from food preparation areas, preferably outside the building. For sewerer properties, the Water Corporation should be contacted for information regarding plumbing requirements and the necessity to have a grease trap, sizing, location etc. For non-sewered areas please contact Environmental Health Services for further advice.

Storage of waste and recyclables

Storage areas shall be pest proof and able to be effectively cleaned. Floor of external storage areas shall be paved, graded, drained and provided with a hose tap. Floor of internal waste storage rooms shall be impervious, coved, graded and drained. Surfaces of walls to be smooth and impervious. Ventilation, pest proofing and hose tap shall be provided.

Ventilation

Sufficient natural or mechanical ventilation shall be provided in cooking areas to effectively remove fumes, smoke, steam and vapours. AS 1668.2 requires that a mechanical exhaust system be provided when:

- Cooking and dishwashing equipment has a total maximum power input of more than 8kW for electrical appliances or total gas input of 29 MJ/h for gas appliances; or
- For any deep fryer appliance; or
- There is more than one piece of equipment within a room and having a total maximum power input exceeding 0.5kW/m² (1.8MJ/m² for gas appliances) of floor area of the enclosure.

NB Microwave ovens are exempted from this requirement.

Lighting

Light fittings in food preparation areas and equipment light/heat fittings shall be designed such that they are easy to clean, flush fitting, provided with covers to contain globes or tubes in case they shatter, and will not harbour insects or dirt.

Floor, Walls and Ceilings

Flooring

Requirements for areas used for food handling, cleaning, sanitising and personal hygiene:

- Shall be able to be effectively cleaned
- Non-absorbent and impervious
- Graded so there is no pooling of water
- Do not provide harbourage for pests

Flooring material shall be appropriate for the activity conducted in the area. Please refer to Table 3.1 of AS 4674 – 2004 for suitability of flooring finishes for food premises areas. Floors draining to a floor waste are to be evenly graded to the drain.

Food preparation areas will generally be required to have one of the following floor finishes:

- Stainless steel with a non-slip profile and welded joints
- Ceramic tiles with epoxy grout
- Sealed quarry tiles
- Polyvinyl sheet with heat welded joints (not suitable adjacent to hot fat appliances)
- Laminated thermosetting plastic sheet with heat welded joints (not suitable adjacent to hot fat appliances)
- Epoxy resins complying with AS 3554

Coving shall be provided at the junction of the floor and walls or plinths where floors are cleaned by flushing with water. Coving is to be an integral part of the floor, plinth and wall surface finish. Coving to have a minimum radius of 25mm. AS 4674 – 2004 includes diagrams showing coving methods.

Plinth finishes shall meet the same requirements as floors, and shall be impervious, rounded at all exposed edges and coved.

Walls and ceilings

Walls and ceilings shall be provided where they are necessary to protect food from contamination, and shall be made of materials appropriate for the activities being conducted. Please refer to Tables 3.2 and 3.3 of AS 4674 – 2004 for suitability of wall and ceiling finishes for food premises areas.

Requirements for walls and ceilings that protect food:

- Shall be able to be effectively cleaned
- Non-absorbent and impervious
- Sealed to prevent dirt, dust and pests getting into the area

Walls of food premises shall be of solid construction to prevent harbourage of vermin in voids and cavities.

Skirting boards, picture rails, open joint spaces, fixing screws, cracks and crevices are not permitted in food premises areas.

Where windowsills are present, they shall be splayed down at an angle so that they cannot be used as a shelf.

Food preparation areas will generally be required to have one of the following wall finishes:

- Stainless steel with welded joints and waterproof screw covers
- Ceramic tiles with an epoxy grout
- Vinyl sheet with heat welded joints
- Aluminium sheet with welded or sealed joints
- Trowelled cement with a polished surface
- Pre-formed panels with H bars joints mastic sealed

Ceilings in food preparation areas shall be finished with impervious sealed material. They shall be non-perforated, free of open joints, cracks and crevices and finished in a light colour to facilitate cleaning. Drop in panel ceilings are not permitted in food preparation and open/unprotected food areas.

Pipes, conduits, electrical wiring and the like shall be concealed in floors, walls, plinths and ceilings. Penetrations and openings are to be sealed. In existing buildings, they can be fixed onto brackets to maintain a 25mm clearance from adjacent surfaces.

Fixture, Fittings and Equipment

Fixture, fittings and equipment shall be adequate for their intended use and designed, constructed and installed such that they are able to be easily cleaned and to allow easy cleaning of adjacent areas.

Cleaning and sanitising of equipment

A food premises selling only pre-packaged food or uncut fruit and vegetables is required to have a minimum of a single bowl sink.

All other food premises require a minimum of a double bowl sink unless all equipment and utensils are sanitised in a dishwasher. In this situation, a single bowl sink would be deemed to be sufficient.

A pot sink shall be provided if necessary to wash larger items. If the equipment needs to be sanitised, a double bowl sink will be required. Additional vegetable preparation and food immersion sinks may need to be provided depending on the type of food being prepared.

Dishwashers/glasswashers are recommended where reusable eating and drinking utensils are used, to enable sanitation requirements to be met.

Sinks shall be provided with a continuous supply of hot and cold running water.

For further information, please refer to Section 4.1 of AS 4674 – 2004.

Hand washing facilities

Hand wash basins shall be provided so that they can be easily accessed in areas where food handlers work ie within 5 metres from food preparation, open/unprotected food, and equipment washing areas. Hand wash basins shall have a permanent supply of warm running water through a single outlet. Taps are to be a 'hands-free' type operation. Liquid soap and single use paper towels, or other approved means of drying hands hygienically, shall be provided for each basin. The basin shall be clearly designated for the purpose of hand washing only. A hand wash basin must also be located immediately adjacent to any toilet facilities.

Food contact surfaces

Food contact surface shall be able to be easily cleaned, impervious and made of materials that will not contaminate food eg stainless steel.

Equipment

Equipment to be installed so that it is either moveable for cleaning, built into walls and vermin-proofed, butted against walls with the joints sealed, or have sufficient clearances from adjacent surfaces as specified in AS 4674 – 2004.

Please refer to Table 4.4 of AS 4674 – 2004 for approved construction materials and specific requirements for fixtures, fittings and equipment.

Equipment to be supported on wheels or castors, plinths, or 150mm high legs (solid metal or capped tubular steel brackets or framework).

Storage of clothing and personal effects

Suitable facilities to be provided eg change room, dedicated lockers or cupboards outside of food handling and food storage areas

Storage of cleaning chemicals and materials

Suitable facility to be provided eg a separate room or enclosed cupboards dedicated for this use only located away from food handling and food storage areas.

Toilet facilities

Provision of toilets for staff and customers is determined in accordance with the Building Code of Australia. Food businesses must ensure that adequate toilet facilities are provided for food handlers. Access to customer toilets shall not be through food preparation areas. Staff toilets shall be located within a reasonable distance from the food handlers' work area.

For enquiries regarding the information contained in this document or should you require an onsite meeting with an Environmental Health Officer please contact:

Email: info@bunbury.wa.gov.au
Post: PO Box 21, BUNBURY WA 6231
In person: 4 Stephen Street, Bunbury
Phone: 08 9792 7100

EXAMPLE: FOOD PREPARATION AREA

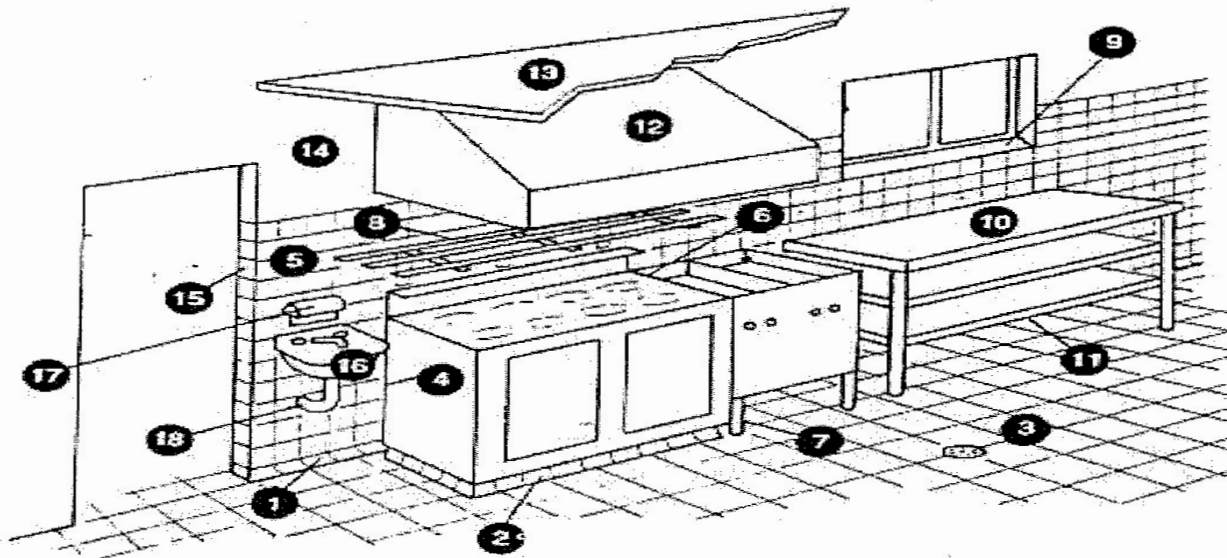

- | | |
|--|--|
| 1. Floor / Wall Coving | 10. Preparation Bench – Steel Framed |
| 2. Plinth | 11. Bottom Shelf 250mm above Floor |
| 3. Impervious Floor Graded and Drained | 12. Mechanical Exhaust Ventilation Canopy |
| 4. Fittings Sealed to Wall or 150mm Clear | 13. Rigid Smooth Faced Ceiling |
| 5. Walls | 14. Smooth Cement Rendering |
| 6. Sealing between Fittings | 15. No Timber Door Frames |
| 7. Legs 150mm min. | 16. Hand Basin, Hot and Cold Water Mixing Set |
| 8. Open Design Racks | 17. Soap and Towel Dispenser |
| 9. Splayed Windowsill 300mm above Prep bench | 18. Water and Drainage Pipes concealed in Wall |

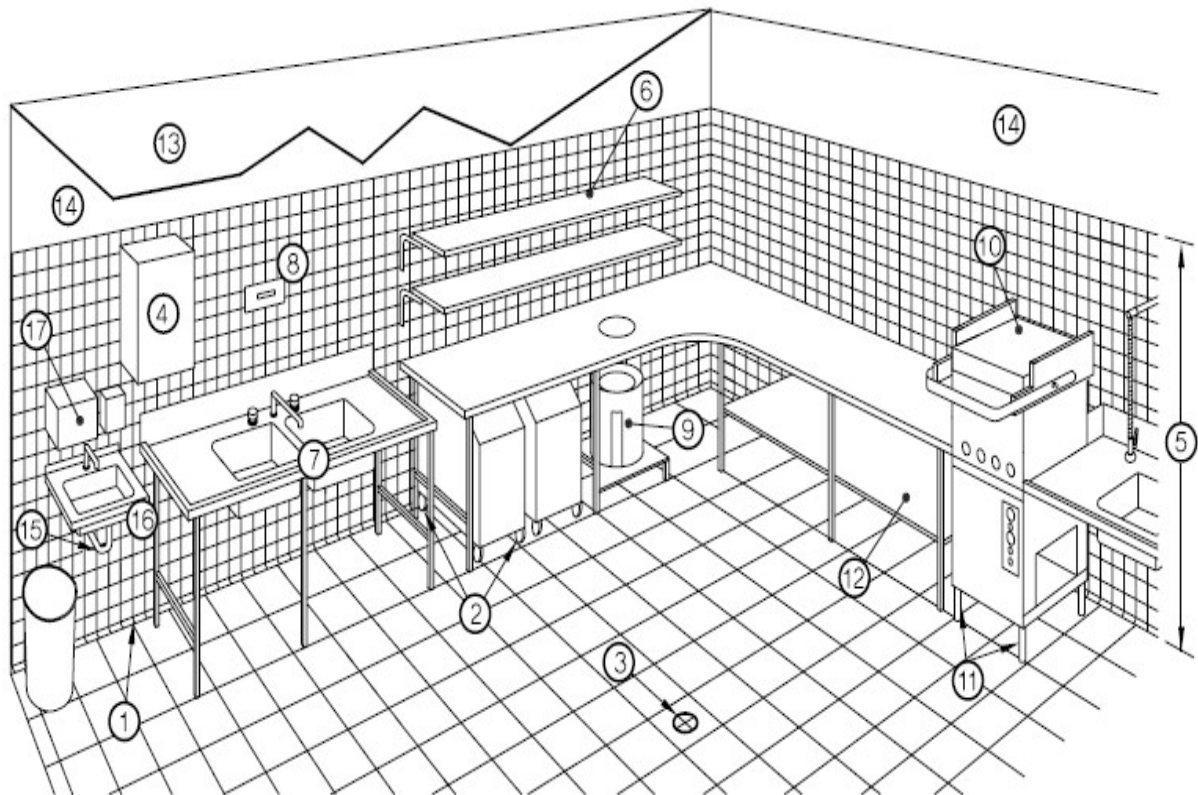

LEGEND:

- | | |
|---|--|
| ① = Floor/wall coving | ⑩ = Dishwasher with temperature indicating device |
| ② = Castors to under bench storage | ⑪ = Legs 150 mm min. |
| ③ = Impervious floor graded and drained | ⑫ = Underside of support bracket 150mm to the finished floor surface |
| ④ = Hot water heater sealed to wall | ⑬ = Painted plasterboard ceiling |
| ⑤ = Walls tiled | ⑭ = Smooth cement rendering |
| ⑥ = Shelving 25 mm clear of wall | ⑮ = Water drainage pipes concealed into walls |
| ⑦ = Sink unit on metal frame | ⑯ = Hand basin, hot and cold water mixing set |
| ⑧ = Thermometer | ⑰ = Soap and towel dispenser |
| ⑨ = Garbage receptacle | |

FIGURE 4.2 TYPICAL WASH-UP AREA